

© Copyright SIRIO antenne - Technical Data are subjected to change - Printed in ITALY - Rev. 09/07/2010 - Cod. ID097

# SD 27 Dipole

CB Base Station Antenna (27 MHz)

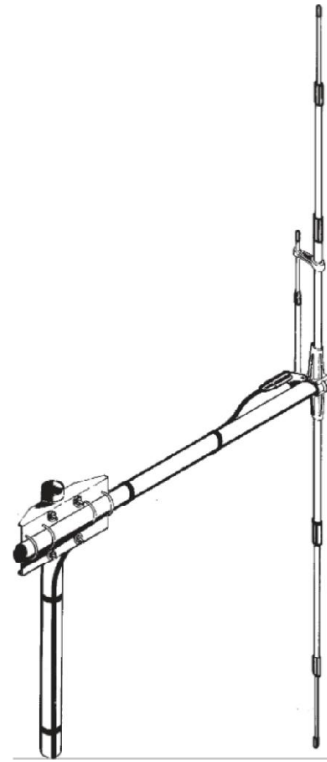

## Installation Manual

### DESCRIPTION

1/2 □ Dipole antenna working on 27 MHz band with Gamma Match System. It has been completely made of anticorrosional aluminium and supplied with Boom and steel bracket for the fitting on the support mast. The fixing part with rapid mounting system is made of die-cast metal to get the maximum strength and robustness. The radial whip is earthed and it is supplied with jointing sleeves of polythene for a perfect water-proofing. Its supplied with UHF Female connector.

### SPECIFICATIONS

Electrical Data		
Type	: Dipole	
Frequency Range	: 26-28 MHz	
Impedance	: 50 Ω	
Radiation	: Horizontal mounting	Directional
	: Vertical mounting	Omnidirectional
Polarization	: Linear Horizontal	
Gain	: 0 dBd - 2.15 dBi	
Bandwidth @SWR≤ 2	: ≥ 3780 KHz (340 channel)	
SWR@ res. freq.	: ≤ 1.1	
Max Power	: 1000 Watts (CW) continuous, 3000 Watts (CW) short time	
Connector	: UHF-female	
Mechanical Data		
Materials	: Aluminium, Nylon, Steel	
Wind Load / Resistance	: 80 N at 150 Km/h / 130 Km/h	
Wind surface	: 0.07 m <sup>2</sup>	
Dimensions (approx)	: 5420 x 1380 x 100 mm	
Boom Length / Diameter	: 1380 mm / Ø 33 mm	
Max. element length	: 5420 mm	
Element Diameter	: Ø 8-12-16 mm	
Turning Radius	: 3050 mm	
Weight (approx.)	: 2560 gr	
Mounting Mast	: Ø 35-50 mm	

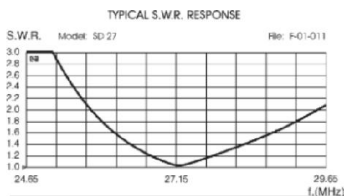

### MOUNTING INSTRUCTIONS

#### 1.0 Assembling of elements

Extract the telescopic elements unstringing the tube Ø 12 and mount the jointing sleeve fixing the first section by means of the supplied phillips screw. Assemble the second jointing sleeve, string the top tube Ø 8 together with its PVC cap and fix the end section by your phillips screw.

#### 1.1 Placing of elements on the Boom

See the picture.

#### 1.2 Assembling of elements to the Boom

String the tuning element of Gamma Match on one element of the radiator dipole, insert the elements into the metal support and fix them by using the screws and key supplied.

#### 2.0 Assembling of Gamma Match

Extract the final tube of Gamma Match to the length L1=485 mm and fix without locking the flat end Ø 12 to the connector by using the supplied nut and washer. Move the tuning element towards the Boom stringing the end part Ø 8 of Gamma Match as far as size L=890 mm. Then fix the tuning element by means of screw and key. Check once again the sizes L and L1, lock the nut on the flat part of Gamma Match and mount the PVC protection cap.

#### 3.0 Assembling of bracket to the Boom

See the picture.

PLEASE, PAY ATTENTION. THE GREAT LOCKING TORQUE OF NUTS THAT FIX THE BOOM CAN CAUSE DAMAGE TO THIS LAST ONE.

#### 3.1 Installation to the support tube

See the picture.

#### 4.0 Cable connection

See the picture.

